

## IMN 70A INOX

### MAGNETIC LEVEL SWITCH

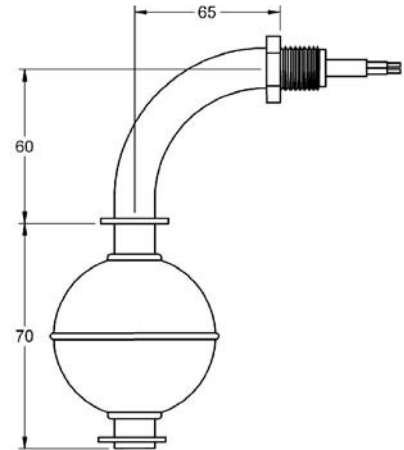

General	Operating principle	IMN level magnetic sensors are based on about <i>reed</i> switches inside the tube, which are activated by a magnet hosted inside the float action and moves to the thrust of the liquid.
	Application	<ul style="list-style-type: none"> <li>For the detection of a single point level in liquids.</li> <li>Used in filling, hollowed out manoeuvres alarm of overflow, etc.</li> </ul>

Housing	Electrical connection	By hose cable of two conductors.
	Length	1 m. Other lengths on request.
	Cable material (Temperature)	Silicone (130 °C) PVC (70 °C)

Body	Guide tube	SS AISI316 (1.4401). Ø12 mm
	Run float	16 mm
	Temperature	-40..+125 °C
	Mounting position	Bent in elbow 90°
	Protection	IP65. Encapsulated with resin epoxy.

Process connection	Thread	1/4" G	
	Material	SS AISI316 (1.4401)	
	E (mm)	6	
	LR (mm)	11	
	LCP (mm)	4	
	e/c (mm)	17	

Floats	Model	FEI601M13
	Material	SS AISI316L (1.4404)
	Dimension (mm)	Ø 52x52
	Pressure (kg/cm <sup>2</sup> )	30
	Density (g/cm <sup>3</sup> )	e > 0,76
	FS / FH (mm)	12,5 / 39,5

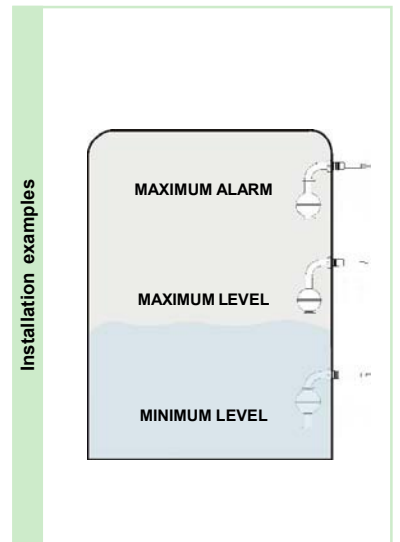

Contacts	Class	120 WVA / 250 VAC-3A
	Type	Reversing the float position, the contact can be NO or NC.
	Situation	

**Microlectra bv.**  
 Augustapolder 12.  
 2992 SR Barendrecht  
 The Netherlands  
 www.microlectra.com  
 info@microlectra.nl

Ordering code IMN 70A INOX